

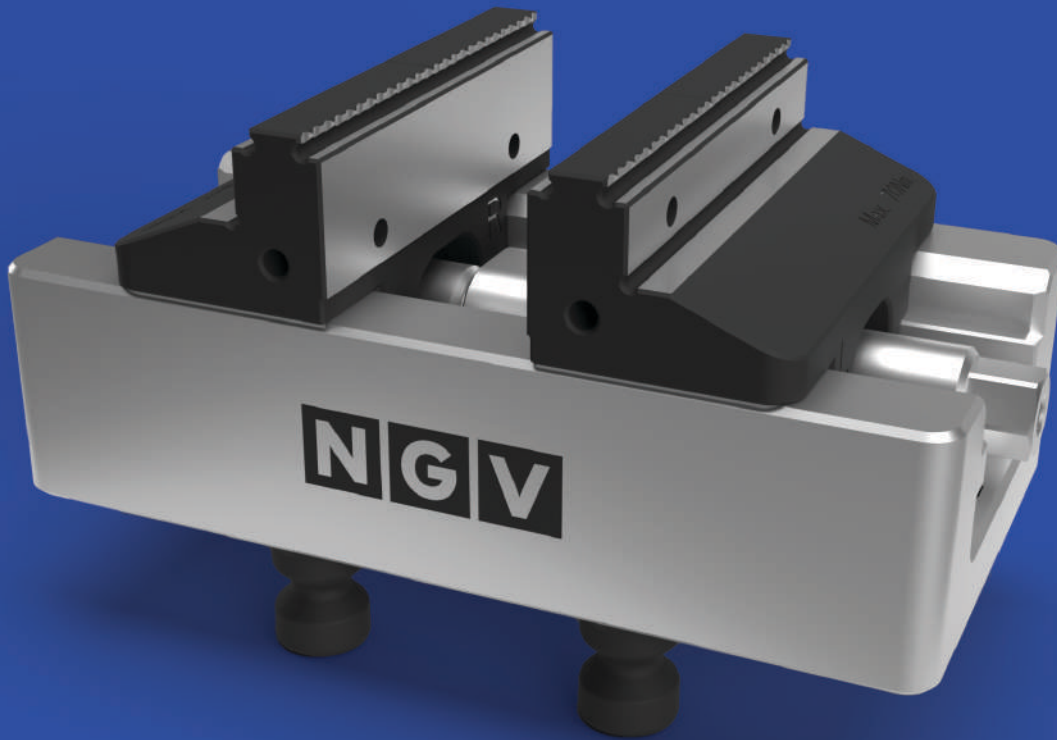

**NOVA GRUP**



**NGV PRODUCTS**

The NGV centring vices have a simple and robust design with a wide range of applications in manufacturing technology. Made with accessibility in mind, NGV vices offer a great benefit to the user and provide an efficient solution in clamping parts. The jaws are reversible and have smooth and serrated zones on both sides which can also clamp pre-stamped raw parts.

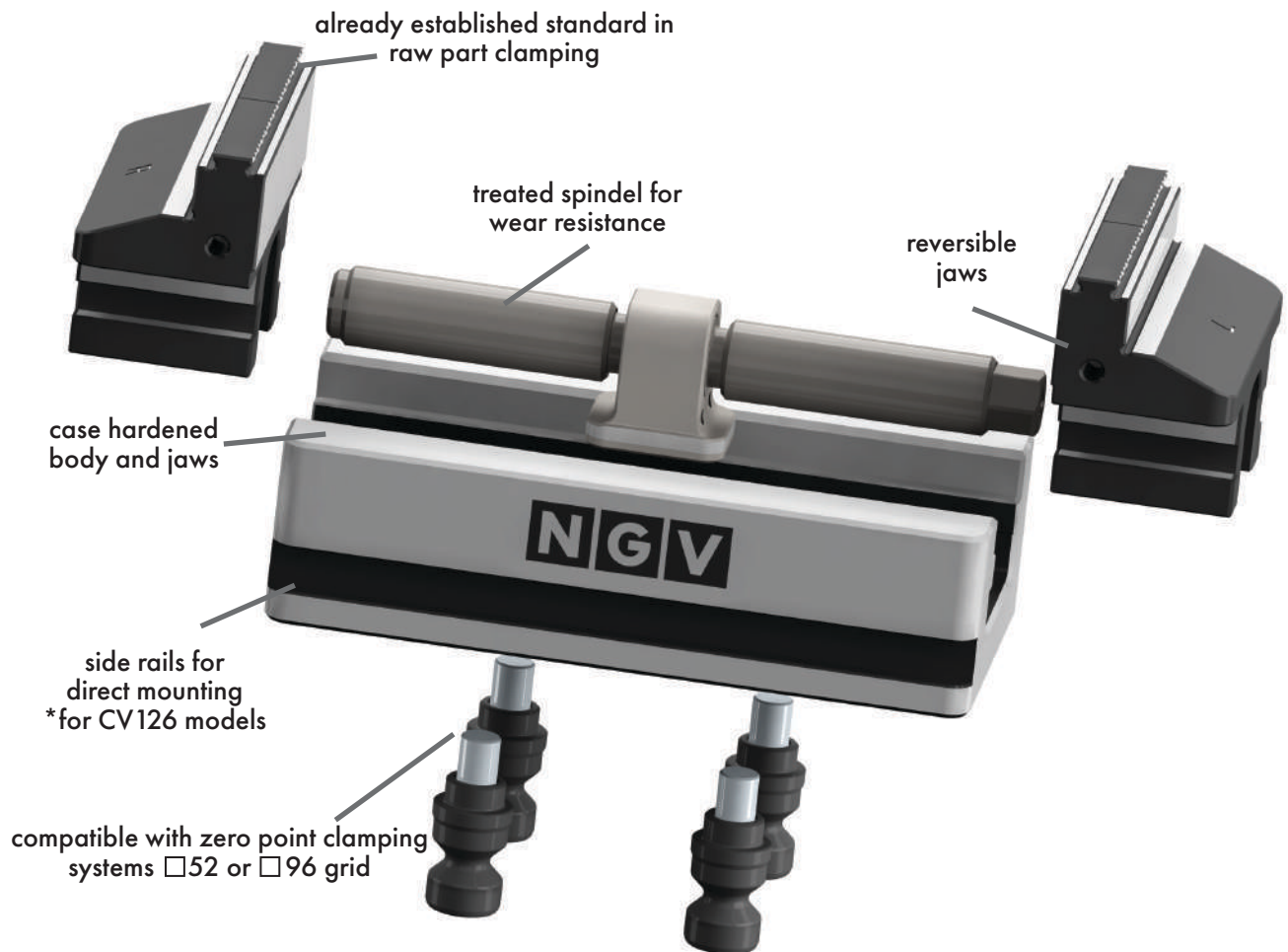

## Compatibility

The vices are compatible with zero point systems in the 52 and 96 grid, but can be also direct mounted with clamps thanks to the available side rails. Made to last, all vices have their body and jaws case hardened and the spindle has a wear resistant treatment. With available accessories one can use soft jaws for custom contour parts.

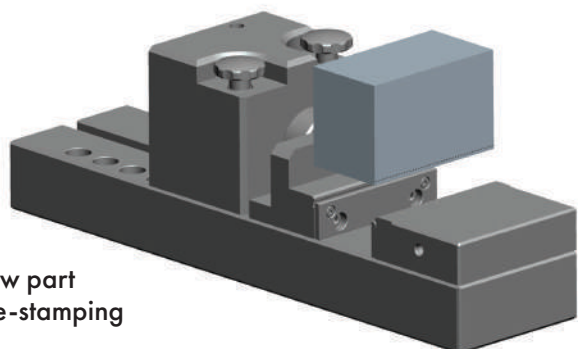

Raw part  
pre-stamping

Pre-stamp the raw part for a better grip in the vice and then use your machine configuration to your own advantage with this simple to use and reliable type of centring vice.

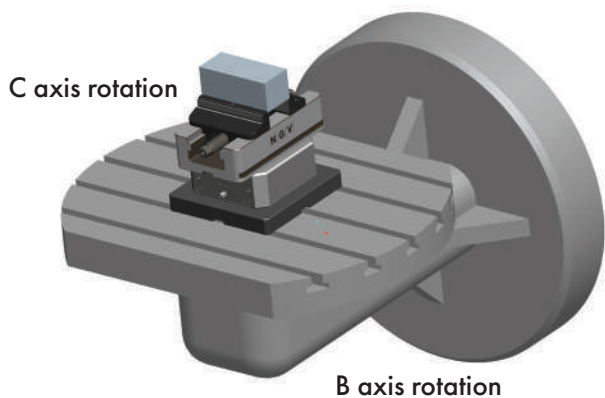

C axis rotation

B axis rotation

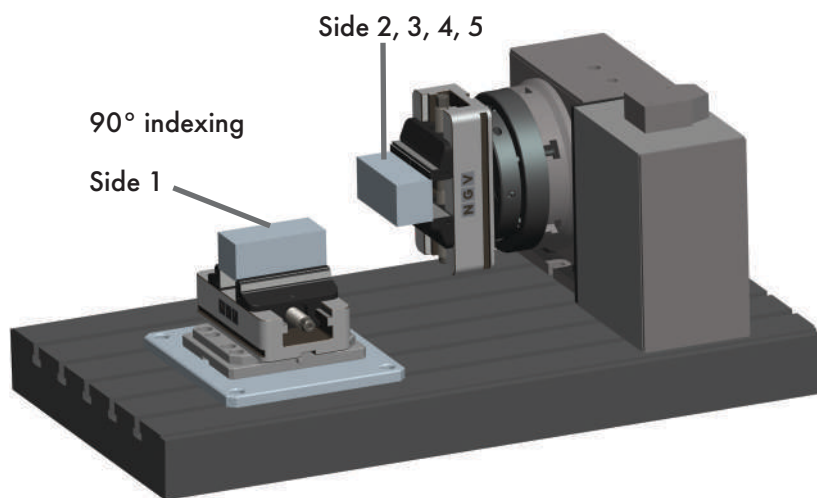

90° indexing

Side 1

Side 2, 3, 4, 5

Depending on how many axis are available on the milling center you can machine 5 out of 6 sides of the part with maximum one changeover of the vice.

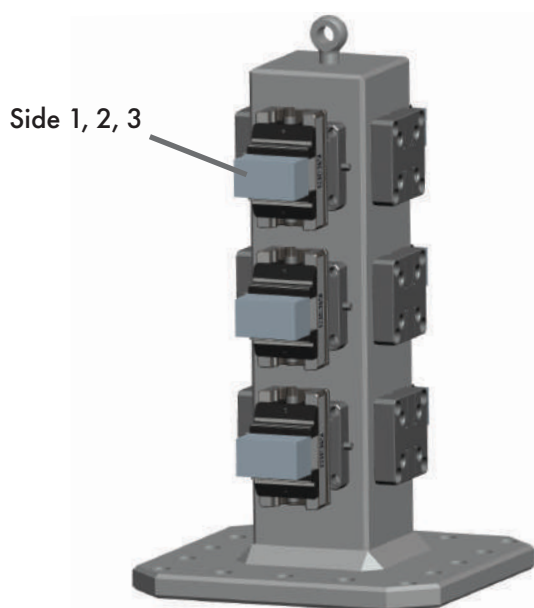

Side 1, 2, 3

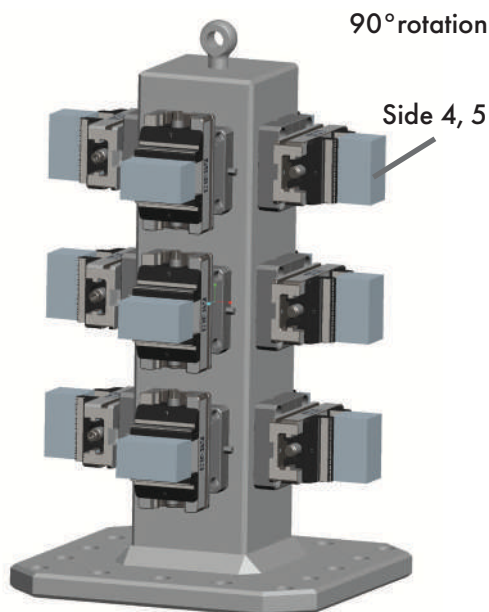

90° rotation

Side 4, 5

You can use the sides of a tower/tombstone or an added 4th axis for a 3 axis machine.

# 5-axis centring vice CV78S

- suitable for zero point clamping systems with 52 grid
- can be used for pre-stamped parts or with smooth surfaces
- reversible jaws
- accessories and spare parts available



jaws can be reversed for a larger clamping range

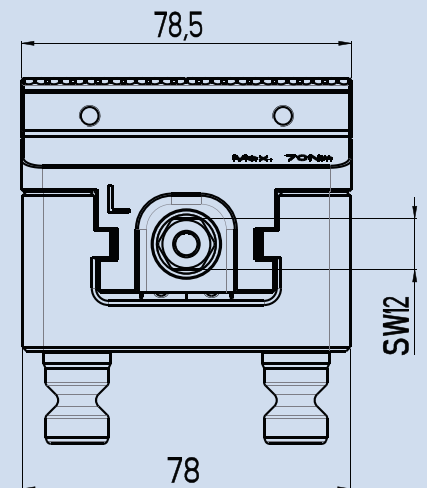
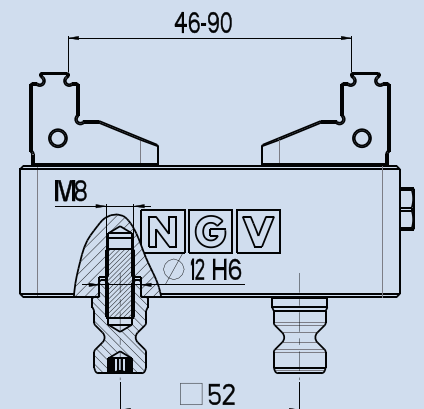
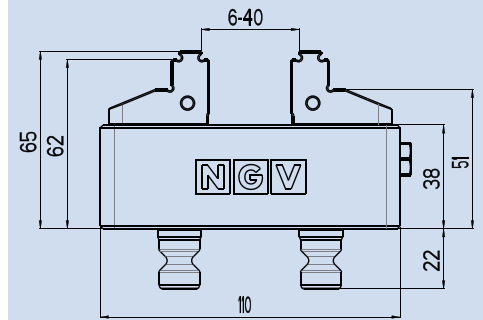

## CV78S

Jaw width	mm	78,5
Body length	mm	110
Clamping range	mm	0 - 90
Zero Point clamping system	mm	□ 52
Zero Point bolt diameter	mm	Ø 16
Tightening torque (max)	Nm	70
Clamping force	kN	14
Centring accuracy	mm	±0,02

### Tightening Torque [Nm]

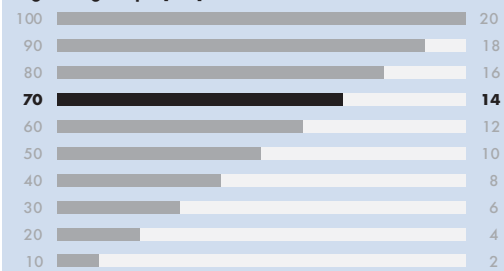

Clamping Force [kN]

# 5-axis centring vice CV78M

- suitable for zero point clamping systems with 52 grid
- can be used for pre-stamped parts or with smooth surfaces
- reversible jaws
- accessories and spare parts available



jaws can be reversed for a larger clamping range

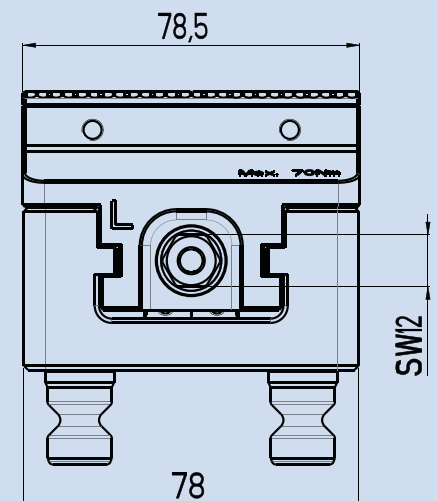
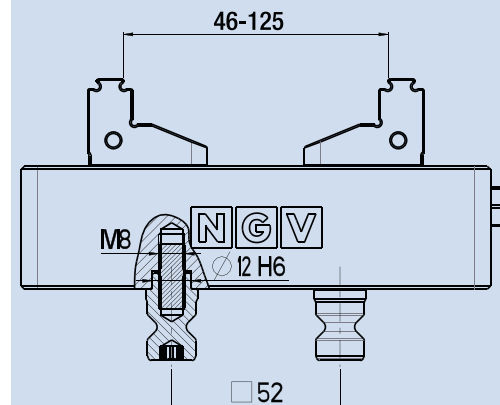
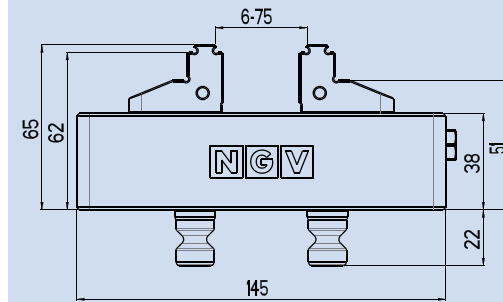

## CV78M

Jaw width	mm	78,5
Body length	mm	145
Clamping range	mm	0 - 125
Zero Point clamping system	mm	□ 52
Zero Point bolt diameter	mm	Ø 16
Tightening torque (max)	Nm	70
Clamping force	kN	14
Centring accuracy	mm	±0,02

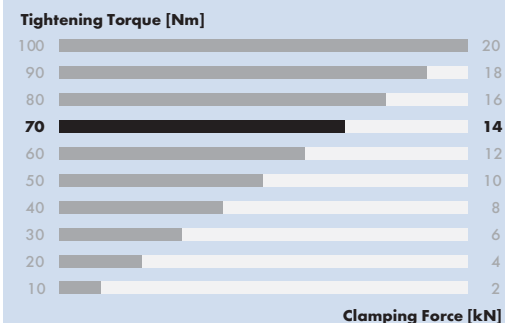

# 5-axis centring vice CV78L

- suitable for zero point clamping systems with 52 grid
- can be used for pre-stamped parts or with smooth surfaces
- reversible jaws
- accessories and spare parts available



jaws can be reversed for a larger clamping range

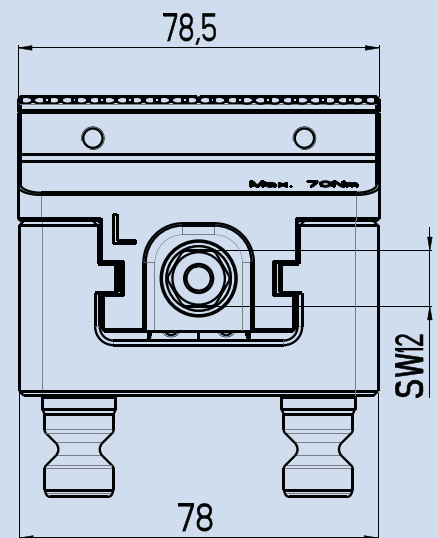
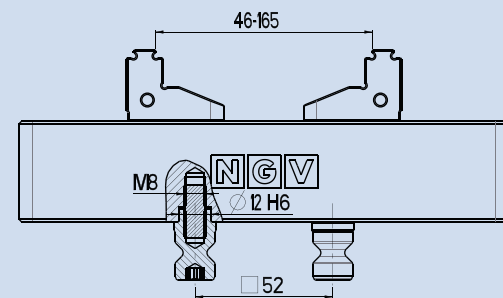
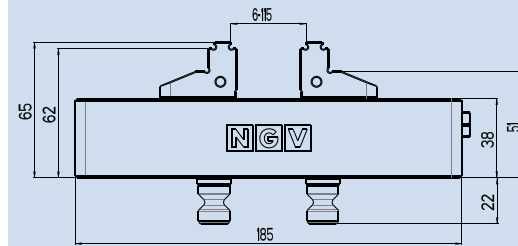

## CV78L

Jaw width	mm	78,5
Body length	mm	185
Clamping range	mm	0 - 165
Zero Point clamping system	mm	□ 52
Zero Point bolt diameter	mm	Ø 16
Tightening torque (max)	Nm	70
Clamping force	kN	14
Centring accuracy	mm	±0,02

### Tightening Torque [Nm]

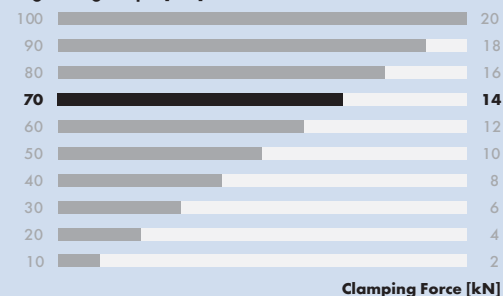

# 5-axis centring vice CV126S

- suitable for zero point clamping systems with 96 grid
- can be used for pre-stamped parts or with smooth surfaces
- reversible jaws
- accessories and spare parts available



jaws can be reversed for a larger clamping range

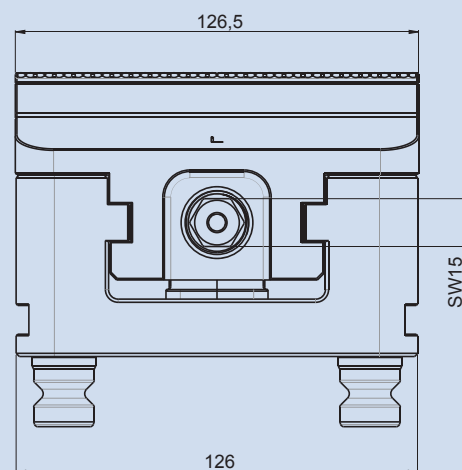
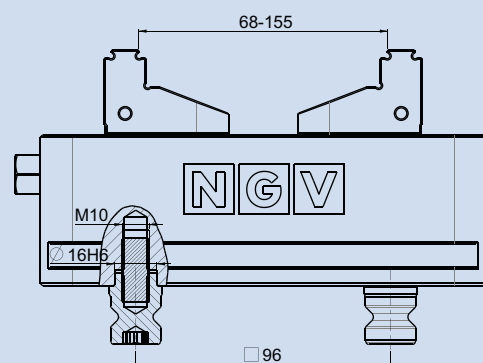
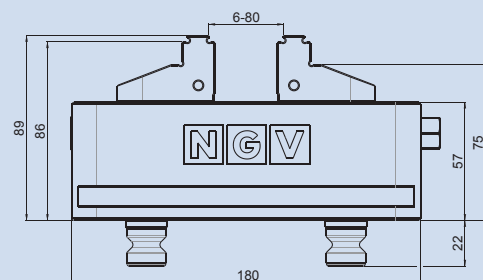

## CV126S

Jaw width	mm	126,5
Body length	mm	180
Clamping range	mm	0 - 155
Zero Point clamping system	mm	□ 96
Zero Point bolt diameter	mm	Ø 20
Tightening torque (max)	Nm	100
Clamping force	kN	20
Centring accuracy	mm	±0,02

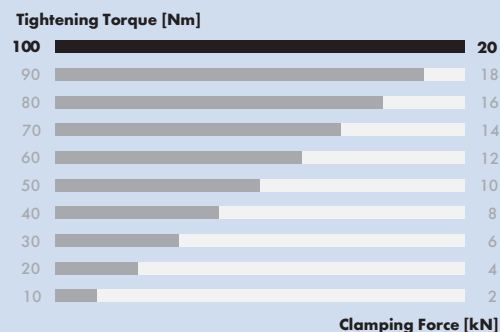

# 5-axis centring vice CV126M

- suitable for zero point clamping systems with 96 grid
- can be used for pre-stamped parts or with smooth surfaces
- reversible jaws
- accessories and spare parts available



jaws can be reversed for a larger clamping range

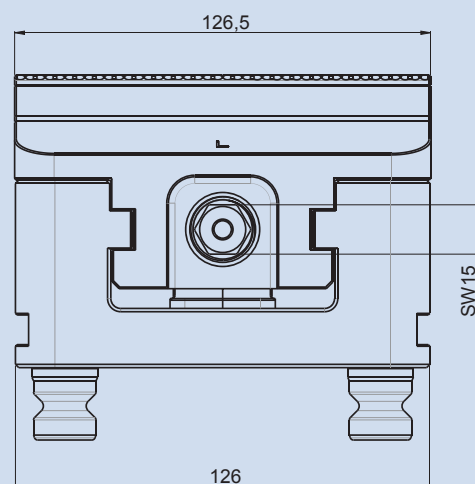
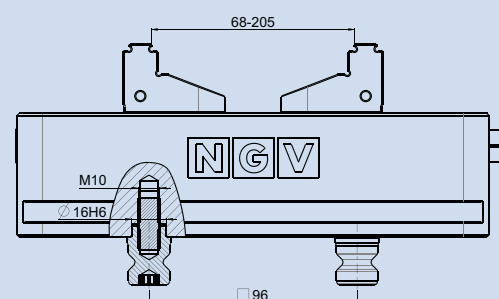
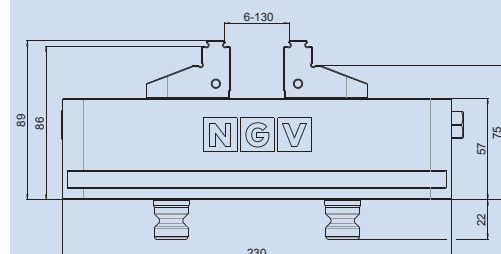

## CV126M

Jaw width	mm	126,5
Body length	mm	230
Clamping range	mm	0 - 205
Zero Point clamping system	mm	□ 96
Zero Point bolt diameter	mm	Ø 20
Tightening torque (max)	Nm	100
Clamping force	kN	20
Centring accuracy	mm	±0,02

### Tightening Torque [Nm]

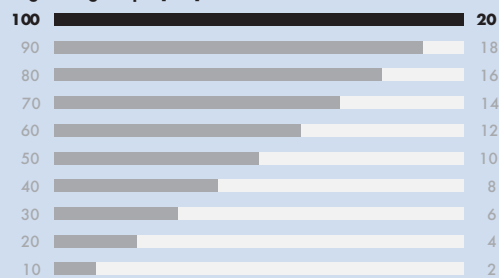

- suitable for zero point clamping systems with 96 grid
- can be used for pre-stamped parts or with smooth surfaces
- reversible jaws
- accessories and spare parts available



jaws can be reversed for a larger clamping range

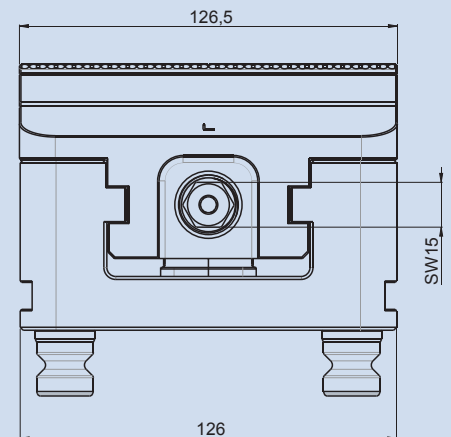
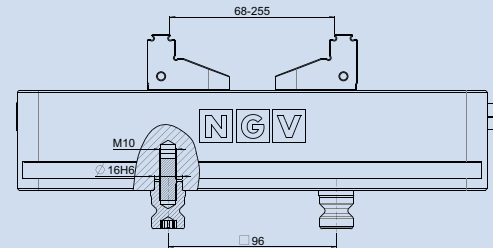
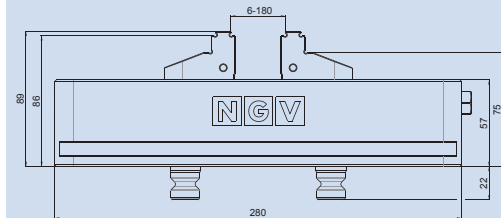

## CV126L

Jaw width	mm	126,5
Body length	mm	280
Clamping range	mm	0 - 255
Zero Point clamping system	mm	□ 96
Zero Point bolt diameter	mm	Ø 20
Tightening torque (max)	Nm	100
Clamping force	kN	20
Centring accuracy	mm	±0,02

### Tightening Torque [Nm]

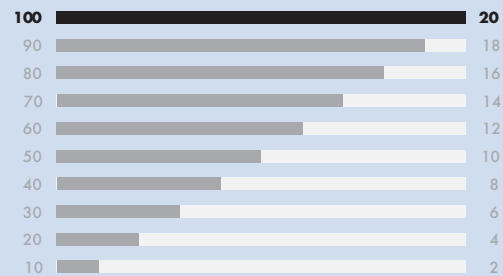

Clamping Force [kN]

# 5-axis centring vice CV48

- suitable for zero point clamping systems with 52 grid
- can be used for pre-stamped parts or with smooth surfaces
- reversible jaws
- accessories and spare parts available



jaws can be reversed for increased clamping range

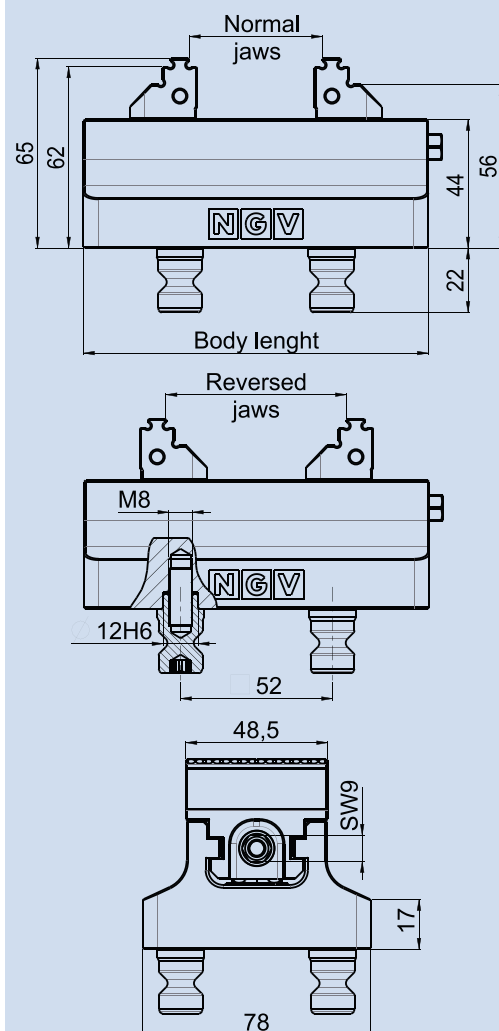

		CV48S	CV48M	CV48L
Jaw width	mm	48,5	48,5	48,5
Body length	mm	78	118	158
Clamping rage normal/reversed jaw	mm	6-40/30-60	6-80/30-100	6-120/30-140
Zero point clamping system	mm	□ 52	□ 52	□ 52
Zero point bold diameter	mm	Ø16	Ø16	Ø16
Max tightening torque	Nm	30	30	30
Clamping force	kN	6	6	6
Centring accuracy	mm	±0,02	±0,02	±0,02

# Dual clamping vice DV78

- This configuration uses the center jaw as the fixed position
- Each side jaw moves independently, allowing the grip of different raw part sizes
- Jaws can easily be reversed for increased clamping range

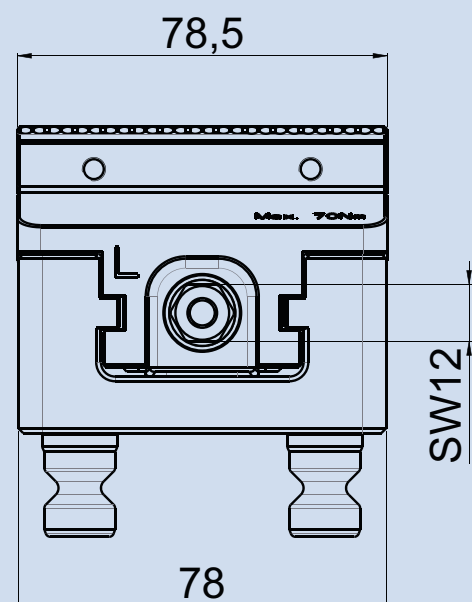
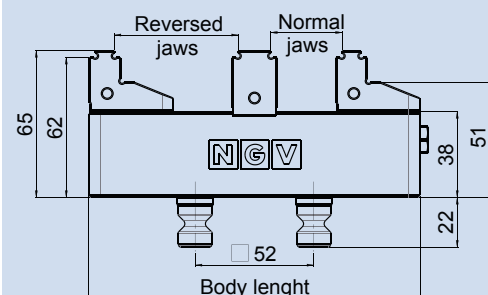

		DV78S	DV78M	DV78L
Jaw width	mm	78,5	78,5	78,5
Body length	mm	110	145	185
Clamping rage normal/reversed jaw	mm	0-15/30-38	0-32/30-55	0-52/30-75
Zero point clamping system	mm	□ 52	□ 52	□ 52
Zero point bold diameter	mm	Ø16	Ø16	Ø16
Max tightening torque	Nm	70	70	70
Clamping force	kN	14	14	14
Centring accuracy	mm	±0,02	±0,02	±0,02

# Dual clamping vice DV126

- This configuration uses the center jaw as the fixed position
- Each side jaw moves independently, allowing the grip of different raw part sizes
- Jaws can quickly and easily be reversed for increased clamping range

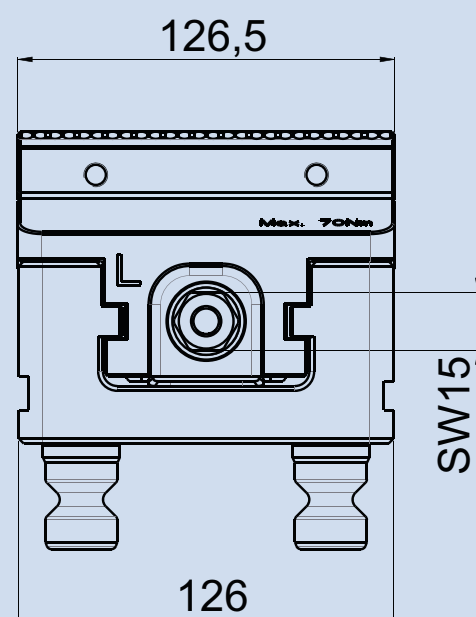
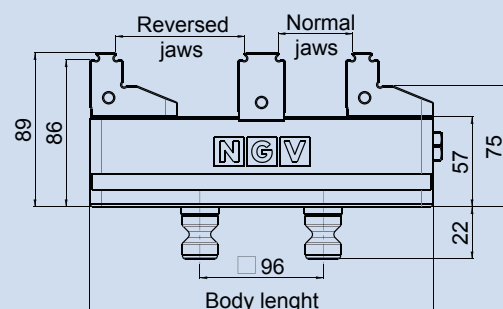

		DV126S	DV126M	DV126L
Jaw width	mm	126,5	126,5	126,5
Body length	mm	180	230	280
Clamping rage normal/reversed jaw	mm	0-38/38-68	0-60/38-95	0-85/38-120
Zero point clamping system	mm	□ 96	□ 96	□ 96
Zero point bold diameter	mm	Ø20	Ø20	Ø20
Max tightening torque	Nm	100	100	100
Clamping force	kN	20	20	20
Centring accuracy	mm	±0,02	±0,02	±0,02

Can be used also with centring pins



jaws can be reversed for a larger clamping range



Includes mounting kit, hand crank and a pair of serrated jaws

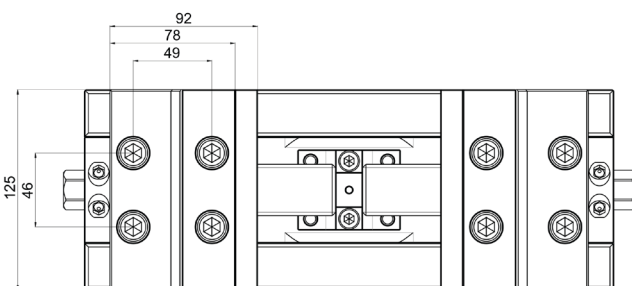
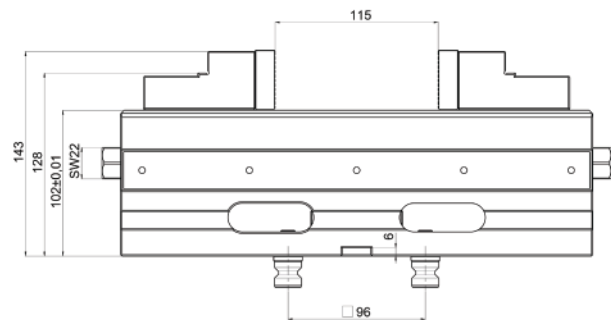

## Features:

- Induction hardened guideways
- Grinded body (GGG60 nodular cast iron)
- For conventional clamping, can be used on machine table or on towers
- Keyways for alignment and H6 locating holes
- Side rails for clamping
- Jaw width 125 mm
- Reversible jaws for larger clamping range
- Heat treated jaws
- Clamping force up to 35 kN@200Nm
- Rigid and robust design
- Side windows for quick cleaning of the inside of the vices
- Equipped with a mechanical spindle without force amplification
- **Centering accuracy 0.015mm**

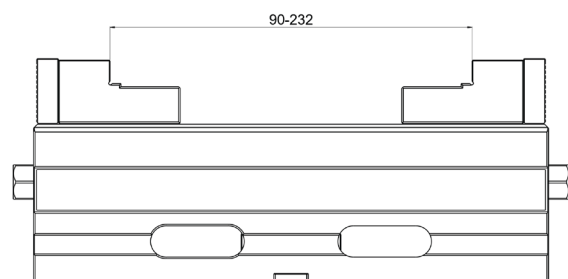
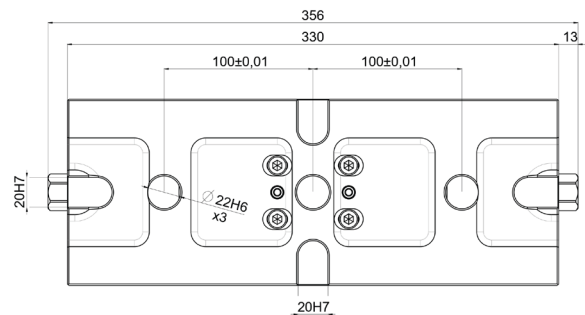

# Precision CNC Machine Vice M125

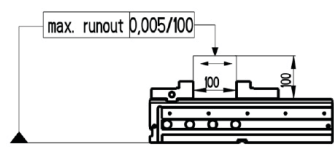
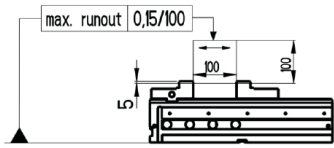
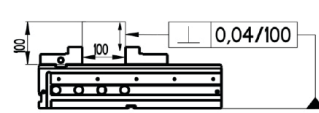
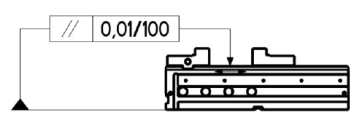
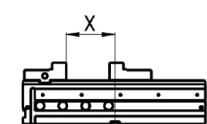

- Induction hardened guideways
- Grinded body (GGG60 nodular cast iron)
- Side rails for conventional clamping
- Can be used on machine table or on towers
- Keyways for alignment and H6 locating holes
- Jaw width 125 mm
- Fixed jaw enhances simple programming thanks to constant zero
- Heat treated jaws
- Clamping force up to 40 kN
- Rigid and robust design
- Maximum clamping range of 355 mm
- Equipped with a mechanical spindle without force amplification
- Wide range of add-on jaws and rail available

	Admissible 0,005mm
	0,15mm
	0,04mm
	0,01mm
	X-122,99-123,04mm

Includes mounting kit, hand crank and a pair of serrated jaws

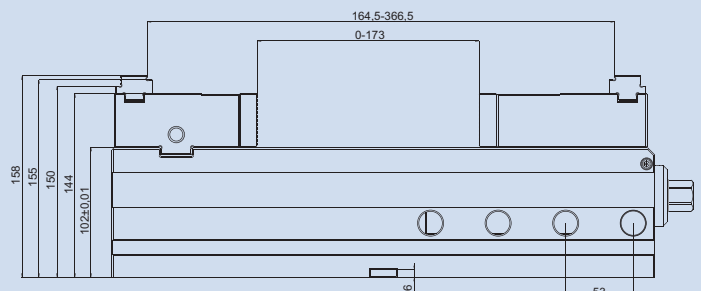
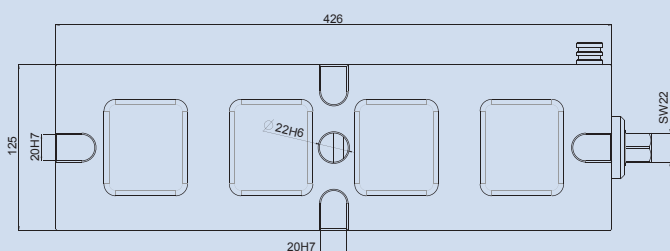

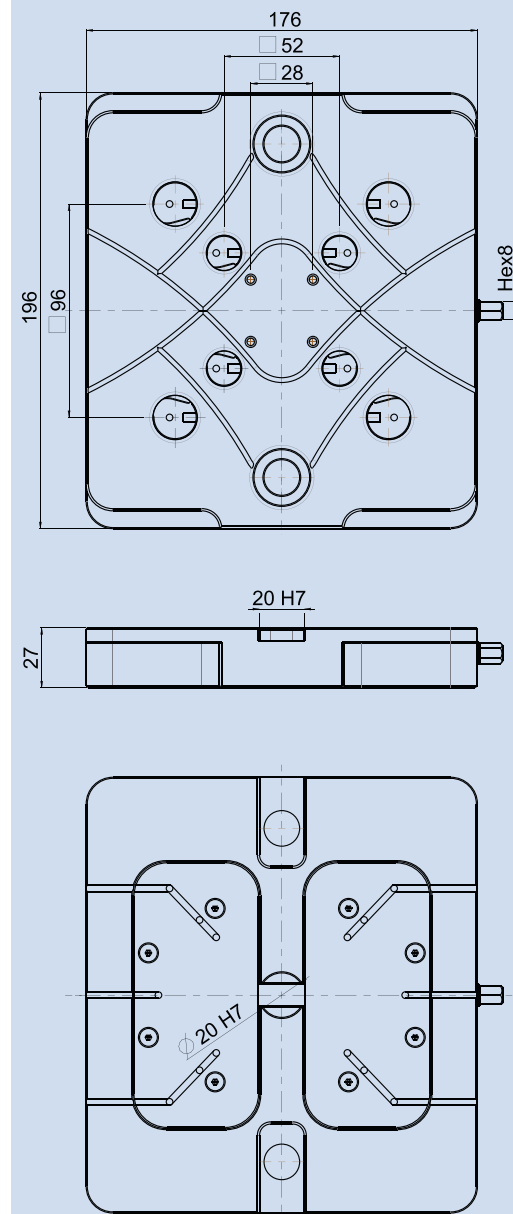

- Repetability less than 10 $\mu$ m
- Industry standard 52 and 96 centring pins spacing in one plate
- Surface treated steel body construction

## PPZ1

Dimensions	mm	196x176x27
Zero point system	mm	□ 96 / 52
Zero point bolts	mm	Ø 20 / Ø 16
Max. tightening torque	Nm	45
Holding force	kN	60
Accuracy	mm	0,01
Suitable vice		CV48/78/126, DV78/126, MC125
Suitable mounting kit		MKS / MKC

## Available Mounting Kits

MKS

MKC



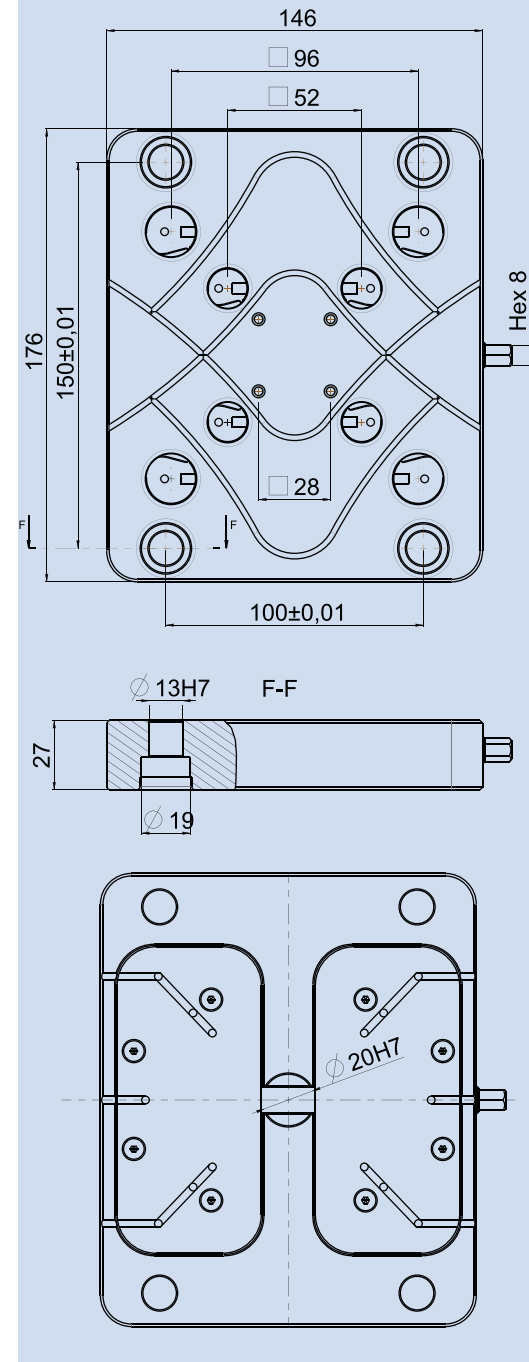

- Repetability less than 10 $\mu$ m
- Industry standard 52 and 96 centring pins spacing in one plate
- Surface treated steel body construction
- Suitable for use on milling centers

## PPZ2

Dimensions	mm	176x146x27
Zero point system	mm	□ 96 / 52
Zero point bolts	mm	Ø 20 / Ø 16
Max. tightening torque	Nm	45
Holding force	kN	60
Accuracy	mm	0,01
Suitable vice		CV48/78/126, DV78/126, MC125
Suitable mounting kit		MKB

## Mounting Kit MKB



High precision positioning due to the Ø13H7 holes and the bushings from the MKB mounting kit.

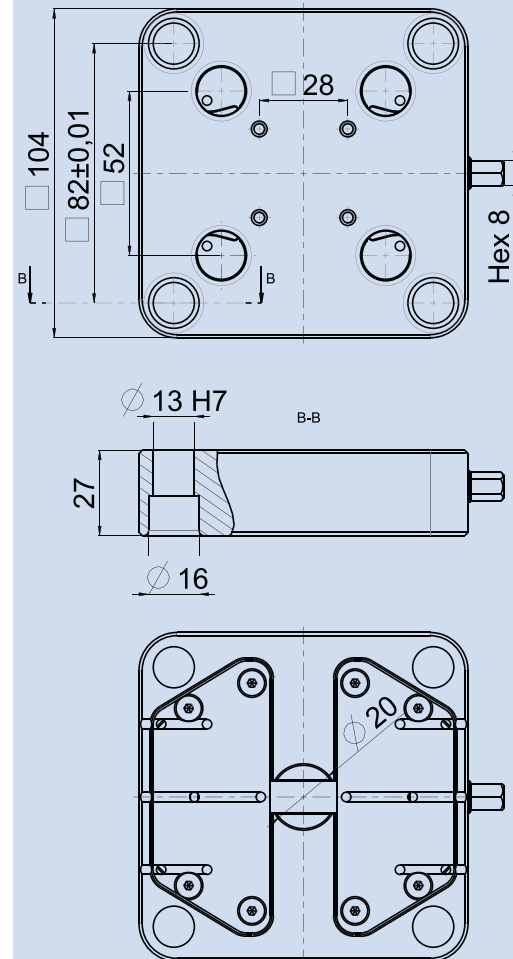

- Repeatability less than 10 $\mu$ m
- Industry standard 52 centring pins spacing
- Surface treated steel body construction
- Suitable for use on milling centers towers

## PPZ3

Dimensions	mm	104x104x27
Zero point system	mm	□ 52
Zero point bolts	mm	Ø 16
Max. tightening torque	Nm	45
Holding force	kN	60
Accuracy	mm	0,01
Suitable vice		CV78 / CV48
Suitable mounting kit		MKB

## Mounting Kit MKB



High precision positioning due to the  $\text{Ø}13\text{H}7$  holes and the bushings from the MKB mounting kit.

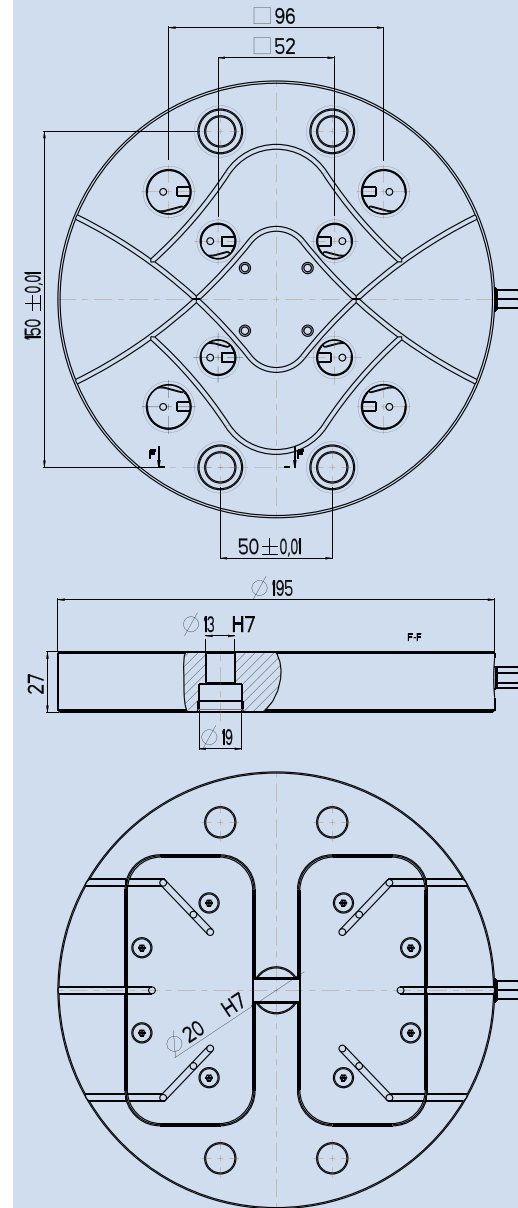
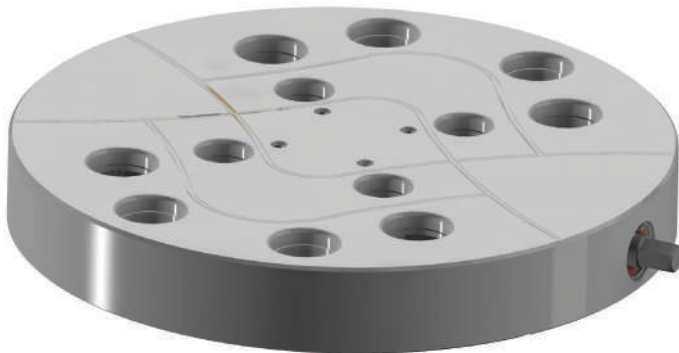

- Repetability less than 10 $\mu$ m
- Industry standard 52 and 96 centring pins spacing in one plate
- Surface treated steel body construction

## PPZ4

Dimensions	mm	$\varnothing 195/27$
Zero point system	mm	$\square 96 / 52$
Zero point bolts	mm	$\varnothing 20 / \varnothing 16$
Max. tightening torque	Nm	45
Holding force	kN	60
Accuracy	mm	0,01
Suitable vice		CV126 / CV78 / CV48
Suitable mounting kit		MKB

## Mounting Kit MKB



High precision positioning due to the  $\varnothing 13H7$  holes and the bushings from the MKB mounting kit.



- Repetability less than 10µm
- Industry standard 52 and 96 centring pins spacing in one riser
- Surface treated steel body construction
- Suitable for use on milling centers

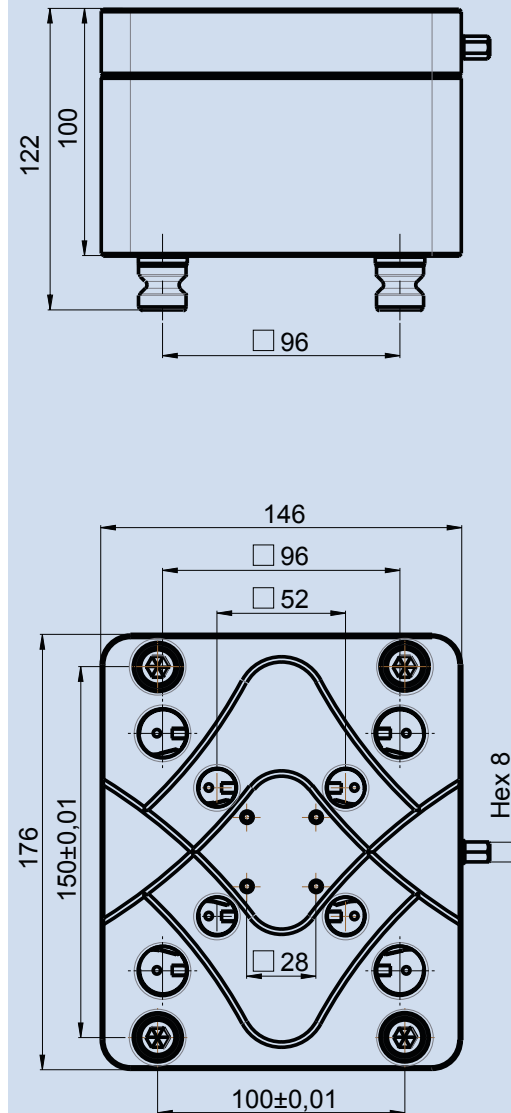

## PPZ5

Dimensions	mm	176x146x100
Zero point system	mm	□ 96 / 52
Zero point bolts	mm	Ø 20 / Ø 16
Max. tightening torque	Nm	45
Holding force	kN	60
Accuracy	mm	0,01
Suitable vice		CV48/78/126, DV78/126, MC125

# Base Jaws // Soft Jaws for CV78 and CV126

- Accessories for flexible clamping
- Adaptation of customer's own device or fixtures on the base jaws
- Positioning is done by bolts
- Base jaws available for 78mm and 126mm widths of NGV centring vices

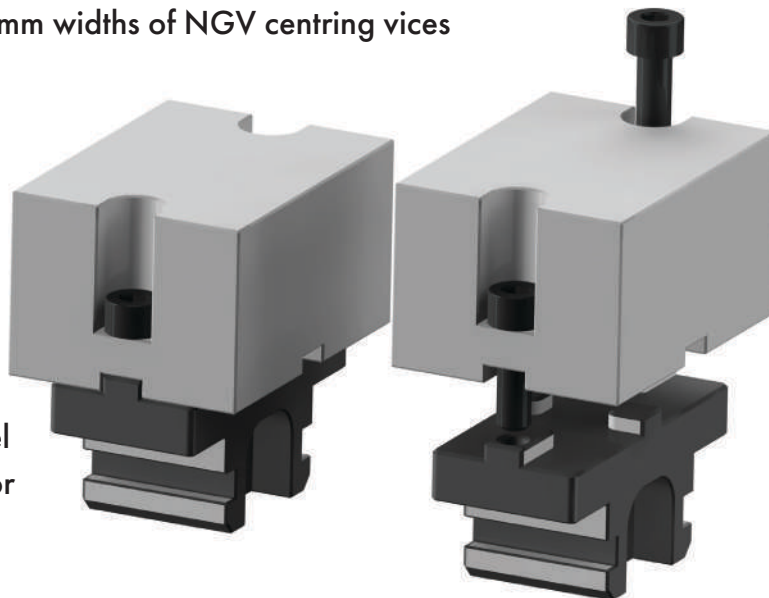

- Soft jaws available in aluminium or steel
- Can be used for pre-machined, round or profiled parts
- Low cost soft jaws can be purchased or can be machined in-house by user

**SJ78  
SJ126**

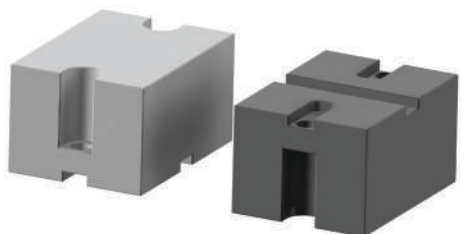

**BJ78  
BJ126**

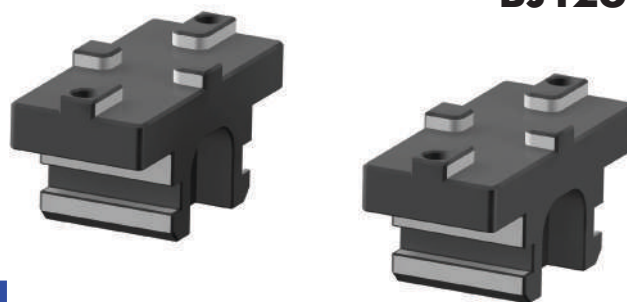

	<b>BJ78</b>	<b>BJ126</b>
Suitable for body width [mm]	78	126
Works with	SJ78A SJ78S	SJ126A SJ126S
Case hardened	55HRC	55HRC

	<b>SJ78A</b>	<b>SJ78S</b>	<b>SJ126A</b>	<b>SJ126S</b>
Suitable for	BJ78	BJ78	BJ126	BJ126
Material	EN AW 5083	1.7139	EN AW 5083	1.7139
L x W x H [mm]	78,5 x 66 x 46	78,5 x 66 x 46	126,5 x 78 x 56	126,5 x 78 x 56

**BJ78/126  
SJ78 /126**

Compatible with zero point clamping systems with 52 grid, this collet chuck uses commercially available collets and speeds up the setup process for milling round parts.

A simple and straightforward design ensures good accessibility with shorter tools and low vibration when used. Available in two sizes for a wide range of clamping diameters.

## ZPC32



## ZPC50

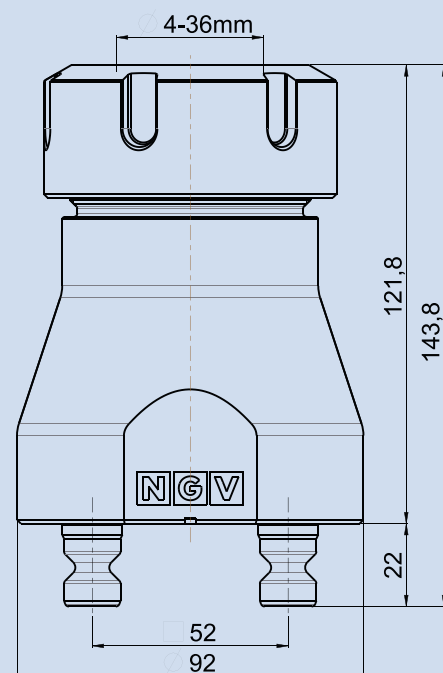
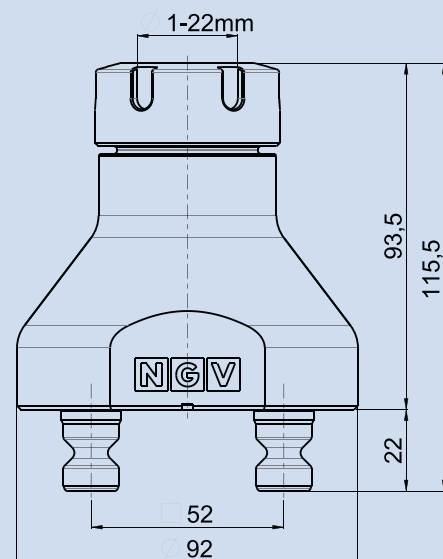

	ZPC32	ZPC50
Compatible with collets for	ER32	ER50
Clamping range [mm]	Ø 1 - 22	Ø 4 - 36
Zero point system [mm]	□ 52	□ 52
Zero point pins diameter [mm]	Ø 16	Ø 16

## ZPC32 ZPC50

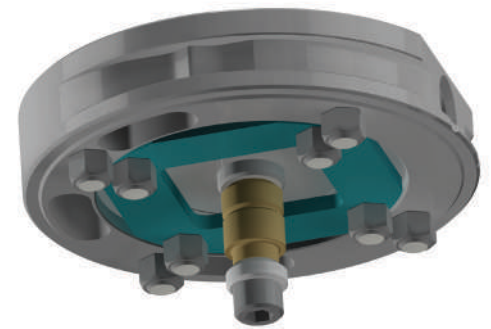

- Aluminum or steel Ø148 pallet
- Compatible with Erowa® Power Chuck P systems
- Includes the centring plate and pins
- Suitable for quick use with centring vices in automations

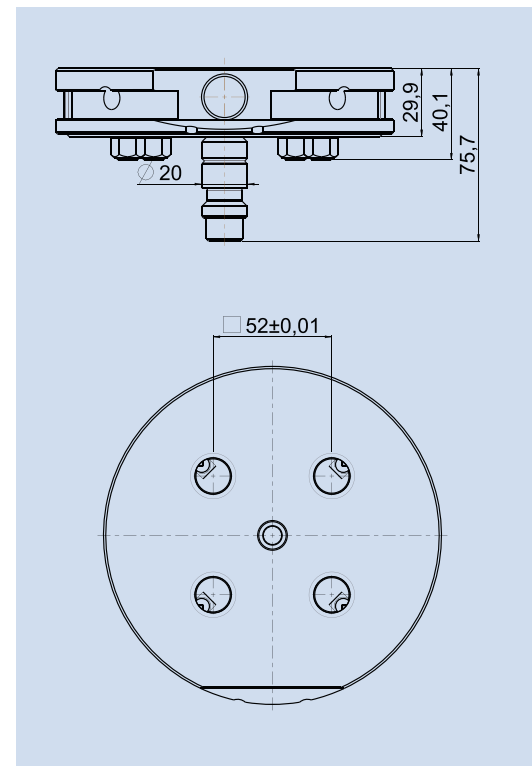
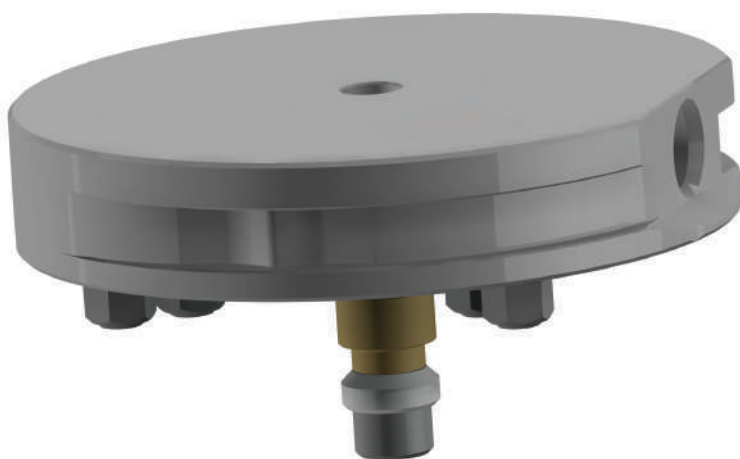

	<b>APE1A</b>	<b>APE1S</b>	<b>APE2A</b>	<b>APE2S</b>
Size	Ø148	Ø148	Ø148	Ø148
Material	EN AW 5083	42CrMo4-QT	EN AW 5083	42CrMo4-QT
Zero point system compatible	Blank	Blank	□ 52	□ 52

**APE1**  
**APE2**

- Replacement jaws for all NGV vices
- Serrated on both sides
- Also with smooth clamping surface for 2nd operations
- Replaceable only in pairs

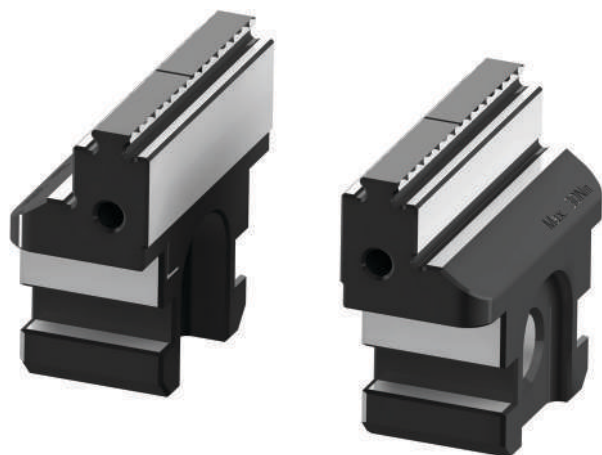

Standard Jaws	J48	J78	J126
Suitable for	CV48	CV78	CV126

- Replacement spindle kits for all NGV vices
- User replaceable

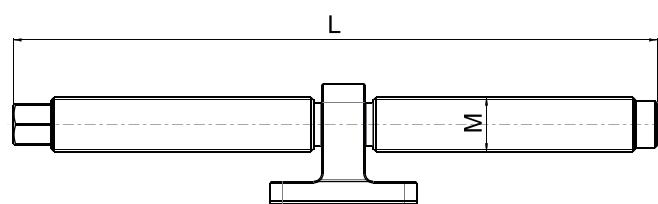

Spindle kits	SK48S	SK48M	SK48L	SK78S	SK78M	SK78L	SK126S	SK126M	SK126L
Length (mm)	82.5	122.5	163	111	146	186	190	237	287
Thread size	M12x1,5	M12x1,5	M12x1,5	M14x1,5	M14x1,5	M14x1,5	M20x1,5	M20x1,5	M20x1,5
Suitable for	CV48S	CV48M	CV78L	CV78S	CV78M	CV78L	CV126S	CV126M	CV126L

- Replacement centring pins

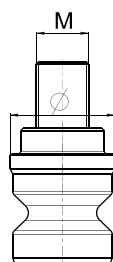

Centring pins	PC16	PC20
Thread (M)	M8	M10
Diameter	Ø16	Ø20
Used with zero point systems	□ 52	□ 96

Plain jaw

AMMH1.5.00.1

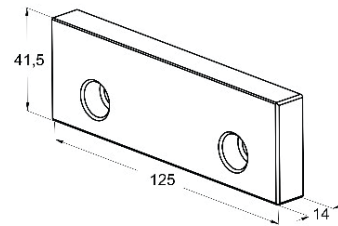
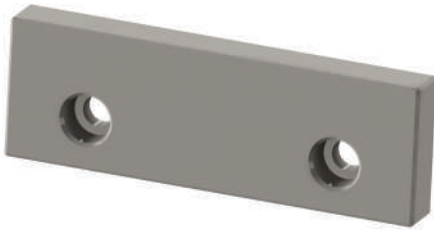

Stepped plain jaw

AMMH1.4.00.1

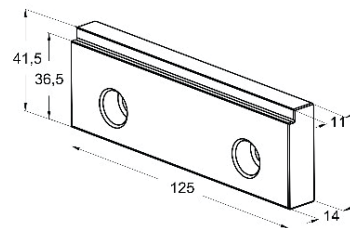

Claw jaw

AMMH1.21.0

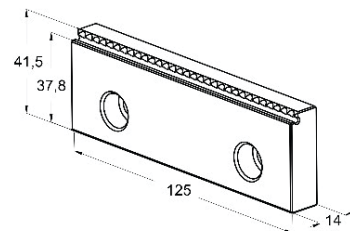
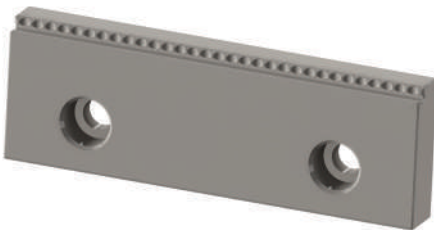

Serrated jaw

AMMH1.1.00.1

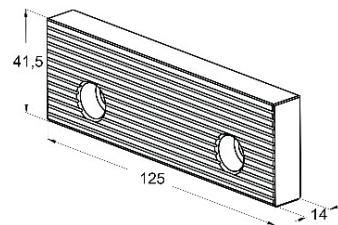
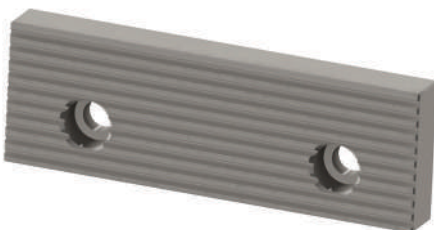

Double serrated jaw

AMMH1.2.00.1

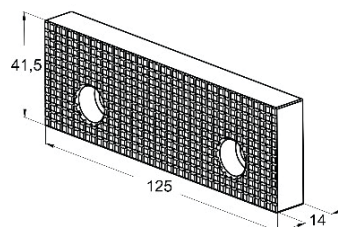
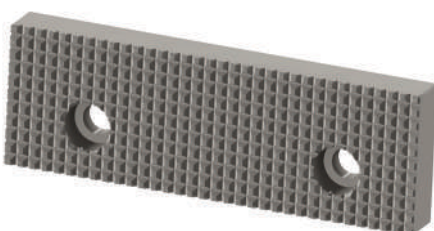

Reversible jaw

AMMH1.19.0

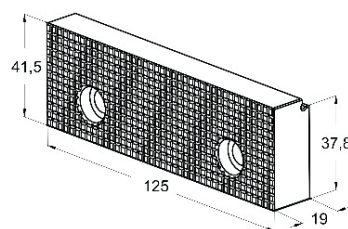

Prismatic jaw

AMMH1.3.00.1

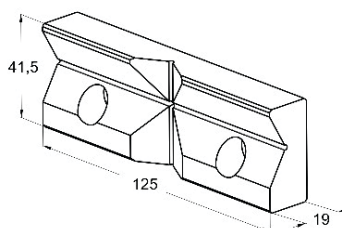
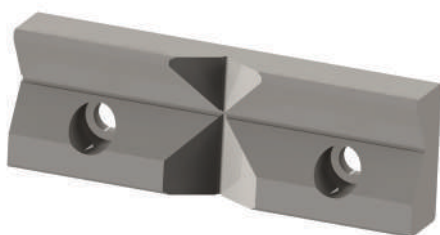

Pull down jaw

AMMH1.6.00.0

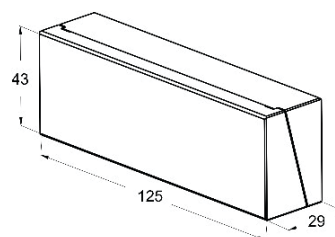
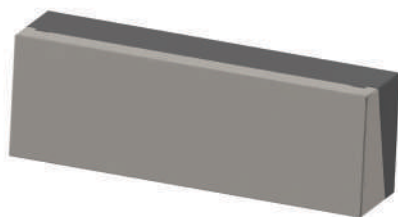

Double serrated rail

AMMM1.4.0

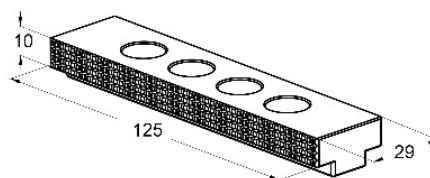

Vice Stoper  
VS1

Mounting kit screw  
MKS

Mounting kit clamp  
MKC

Mounting kit bushing  
MKB



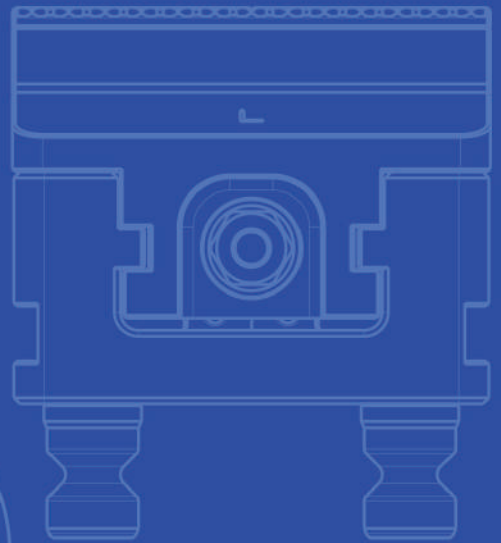
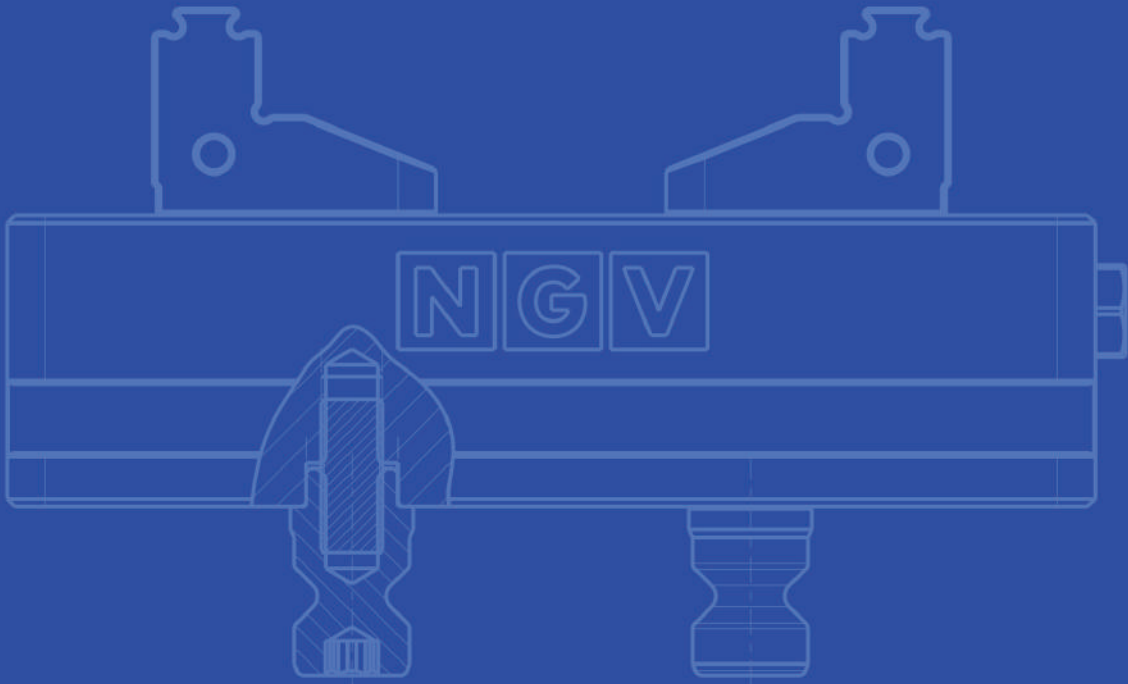

**NGV**  **NOVA GRUP**

22 Victoriei Str, 515600 Cugir, Romania

[ngv@novagrup.ro](mailto:ngv@novagrup.ro)

[ngv.novagrup.ro](http://ngv.novagrup.ro)